

Cognize Normal-Like Pleez

Video Installation

by

John Paul Lempke

A Thesis Presented in Partial Fulfillment
of the Requirements for the Degree
Master of Music

Approved April 2018 by the
Graduate Supervisory Committee:

Kotoka Suzuki, Chair
Kristina Knowles
Chris Stover

ARIZONA STATE UNIVERSITY

May 2018

ABSTRACT

I believe the human mind is not an accurate reproducer of objects and events, but a tool that constructs their qualities. Philosophers Bowman Clarke, James John, and Amy Kind have argued for and against similar points, while Daniel Hoffman and Jay Dowling have debated cases from a psychological perspective.¹ My understanding of their discourse surfaces in *Cognize Normal-Like Pleez*, a video installation designed to capture the enigmatic connection between perceivers and the things they perceive. The composition encapsulates this theme through a series of five videos that disseminate confusing imagery paired with mangled sounds. The miniatures operate in sequence on computer monitors set inside a haphazardly ornamented tower. Though the original sources for each video communicate clear, familiar subjects, the final product deliberately obscures them. Sometimes sounds and images flicker for only brief moments, perhaps too fast for the human mind to fully process. Though some information comes through, important data supplied by the surrounding context is absent.

I invite the audience to rationalize this complexing conglomerate and reflect on how their established biases inform their opinion of the work. Each person likely draws from his or her experiences, cultural conditioning, knowledge, and other personal factors in order to create an individual conceptualization of the installation. Their subjective conclusions reflect my belief concerning a neurological basis for the origin of qualities.

One's connection to *Cognize's* images and sounds, to me, is not derived solely from

¹ Bowman Clarke, "Qualia, Extension, and Abstraction," *The Monist* 69, no. 2 (1986): 216-34; Jay W. Dowling, "Qualia as Intervening Variables in the Understanding of Music Cognition," *Musica Humana* 2, no. 1 (2010): 1-20; Daniel Hoffman, "Conscious Realism and the Mind-Body Problem," *Mind & Matter* 6, no. 1 (2008): 87-121; James John, "Against Qualia Theory," *Philosophical Studies* 147, no. 3 (2010): 323-46; Amy Kind, "Qualia Realism," *Philosophical Studies* 104, no. 2 (2001): 143-62.

characteristics inherent to it, but also endowed by one's mind, which not only constructs the attributes one normally associates with the images and sounds (as opposed to the physics and biology that lead to their construction), but also seamlessly incorporates the aforementioned biases. I realize my ideas by focusing the topics of the videos and their setting around the transmission of information and its obfuscation. Just as one cannot see or hear past the perceptual barriers in *Cognize*, I believe one cannot escape his or her mind to "sense" qualities in an objective, disembodied manner, because the mind is necessary for perception.

ACKNOWLEDGMENTS

I would like to thank the ASU Prototype and Modeling Shop for helping in the construction of this project, as well as Rick Florence for his practical advice, and Kotoka Suzuki for her support as my instructor this past year. Finally, the Herberger Institute for Design and the Arts has made the realization of this project possible through the generous contribution of a creative grant. They deserve my full gratitude.

TABLE OF CONTENTS

	Page
SCORE	
TITLE.....	1
ABOUT	2
VIDEO/MUSIC	5
MATERIALS	6
CONSTRUCTION	7
PHOTO EXAMPLES	13

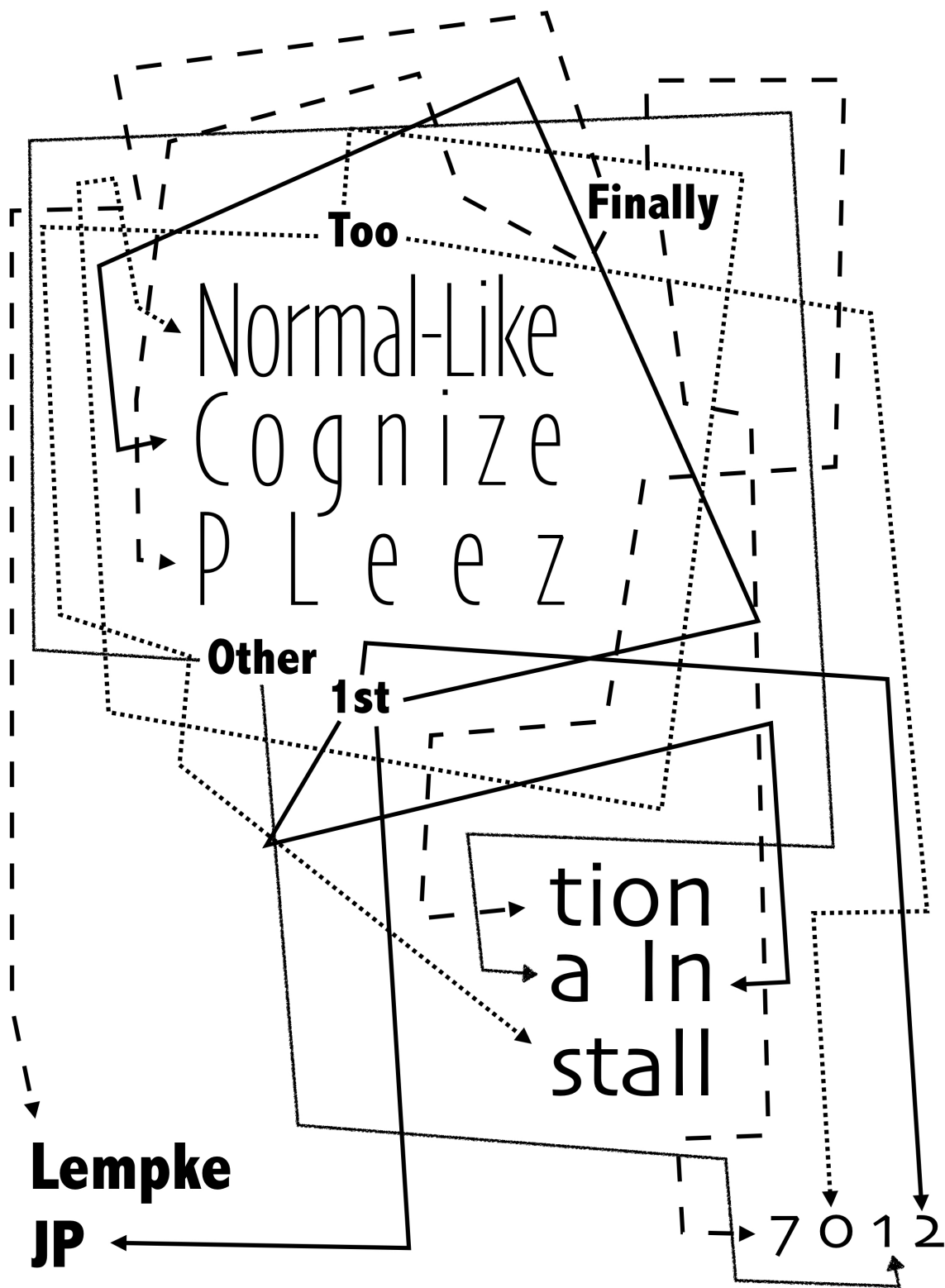

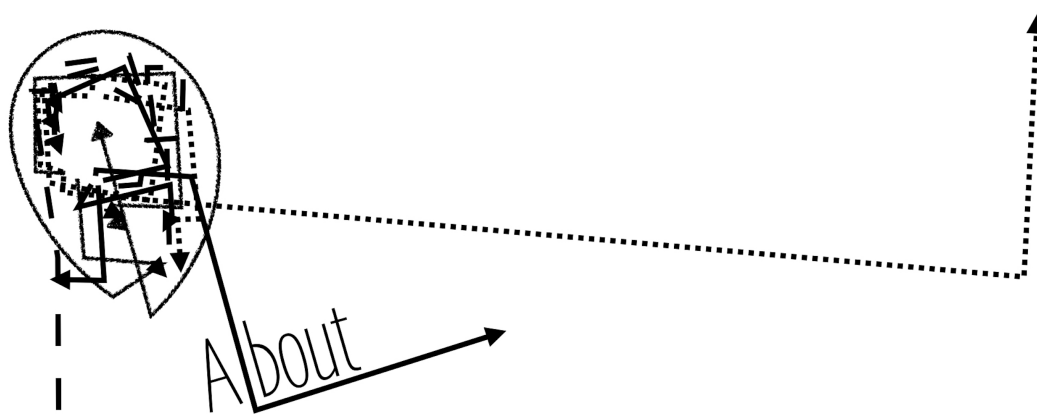

My hobby in abstract visual art has drawn my attention towards the (automatic/willful) manner in which people superimpose familiar imagery on top of lines, spaces, shadings, and colors within and among non-representational objects. To one friend, a splattering of paint and rubber cement across a canvas becomes a swan; to another, a few broad strokes of different colors becomes a planet and moon. People's tendency to use metaphors in order to manage and control otherwise unorganized data extends to my compositional practice as well. An acquaintance of mine described one of my pieces for two electric guitars using an elaborate space-whale narrative, and an audience member who witnessed one of my organ works thought about it in terms of nocturnal creatures.

These anecdotes speak to the individual manner in which I believe human beings couple sensory data with past experiences, superimposing one atop the other. The unfamiliar/unclassifiable art and music becomes familiar and comprehensible when one "recognizes" features that s/he may have never seen before. Circularly enough, it seems to me that depictions of things, intentional or otherwise, come to represent the things they depict by visually imitating lines and shadings and/or auditorily imitating inflections, pitch levels, and timbre. Human creations, thus, reveal to me how people utilize a variety of characteristics to define and classify things/events. When I as the artist or a composer imitate a particular set of characteristics, even loosely, individuals tend to associate my portrayal with the thing/event itself.

Repeated experiences in these matters have led me down another related train of thought. Perhaps the representations of things in art and music can act as an analogy to the perceptual connection between an observer and the information the observer observes. Much in the same way that the qualities an artist or composer imitates in order to depict a thing/event are present within it, the thing/event itself must derive its qualities from somewhere, somehow. So the question occurs to me, does the sound of the electric guitar space-whale cry emerge from the instrument or in my head? My inquiry does not concern the origin of the pressure waves that reach my ears, but rather the experience I have from listening.

The manner in which humans process the information we glean is two-sided, involving not only our cognitive faculties, but (necessarily) the nature of the information itself. Whether qualities are inherently present in the world around us or merely a result of interpretations by the brain raises important questions about the nature of experience and the relationship between conscious beings and the elements in the environment that we name, recognize, and describe. Many philosophers have stated their opinions on the subject, such as Bowman Clarke, James John, and Amy Kind, and psychologists like Jay Dowling and Daniel Hoffman have assessed the issue as well.¹

1. Bowman Clarke, "Qualia, Extension, and Abstraction," *The Monist* 69, no. 2 (1986): 216-34; Jay W. Dowling, "Qualia as Intervening Variables in the Understanding of Music Cognition," *Musica Humana* 2, no. 1 (2010): 1-20; Daniel Hoffman, "Conscious Realism and the Mind-Body Problem," *Mind & Matter* 6, no. 1 (2008): 87-121; James John, "Against Qualia Theory," *Philosophical Studies* 147, no. 3 (2010): 323-46; Amy Kind, "Qualia Realism," *Philosophical Studies* 104, no. 2 (2001): 143-62.

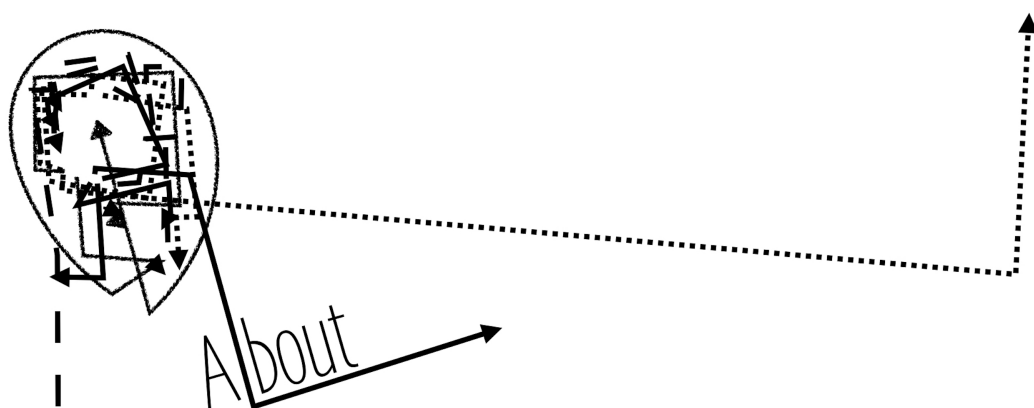

Drawing from these and other resources, I have over time come to believe that the qualities of everything we observe resides in our consciousnesses, not in the outside world. Our sensory organs translate things (or events) into electrical impulses that the brain interprets to be the thing (or event) itself, rather than the impulses. This is not to say that reality “isn’t real,” but rather a commentary on how the properties of our reality arise in the individual mind. To me, characteristics are a result of the senses and essential for consciousness. I find it impossible to imagine a universe devoid of the qualities I automatically/willfully impose upon it. The world in my philosophy is an interpreted one—a construction, so to speak—and its apparent qualities evidence not an environment with all its familiar characteristics injected into its folds, but just one of many (theoretically possible) renderings of existing data.

Art and music can help draw attention to the relationship between the world as qualified by the human mind and the universe to which connects, sometimes by actually depicting things as we perceive them and sometimes by lying purely in the abstract. I find that, by doing so, they highlight the nature and origin of the characteristics that constitute our reality and the indispensable function of the brain within the process of generating those characteristics.

Cognize Normal-Like Pleez takes this role of art and music and expresses it through deliberate obfuscation of otherwise clear imagery. The observer is invited to watch a series of videos construed in a haphazard setting. None of the media builds into a clear storyline, nor does it always give obvious clues to the source material. Rather, each audience member can either fabricate their own connections between disparate elements or reject it all as meaningless drivel. The massiveness of the project represents the scope of the issue (whatever the size of one’s entire conscious experiences may be). If one sees or hears it (or smells it...or tastes it), he or she confronts, cognizes, and rationalizes it...or perhaps fails to. In a sentence, the work coaxes us into make sense of our experiences with it.

The imagery and the videos create an absurd, nonsensical atmosphere, which together define a confusing, yet somehow cohesive, space. Both the setting and the videos center around the transmission of information. By filtering and distorting the elements of the transmitted information, I hope to create an analogy to perception and its qualities. In this case, the manipulated sounds and images represent qualities that the mind imposes on the things/ events it comprehends, while the original, unedited videos represent the things/events devoid of the characteristics imposed by the brain (perhaps an impossible task to imagine). “Things,” in this case, refers to anything that seems to unite into a single entity, while “events” refers to the actions of things over time. Needless to say, one cannot access the original contents, only their filtered and distorted versions.

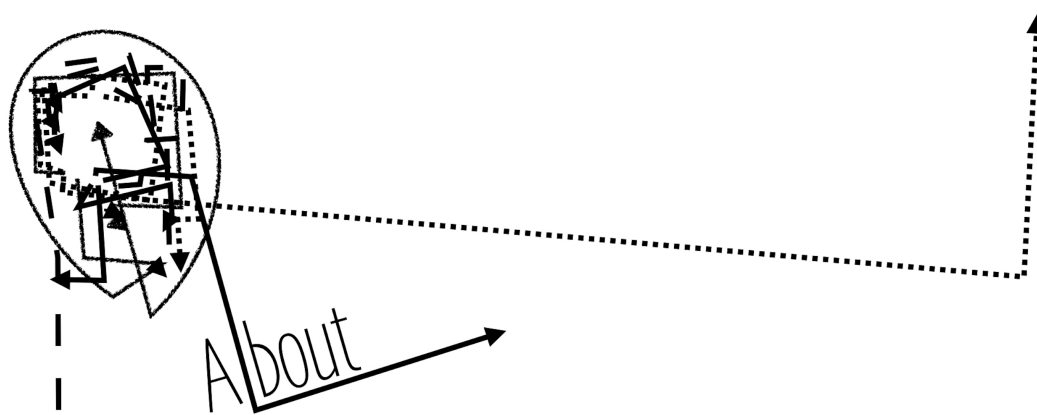

Each video in the sequence presents this theme in a different manner. First, a large object dances near the camera lens atop a background of pulsating light and darkness. A series of sounds respond to its jumpy movements, but the images neither cohere into a plot nor provide any explanations. In the next scene, a violinist performs a common tune across a busy road while traffic passes in front, effectively drowning the intended communication in white noise. An explanation of the work follows, one word (or one syllable) at a time. The phrases, however, pass by too quickly for any individual to completely register them, and the obscure, awkward terminology distracts from the broader meaning, as do the brief snippets of sound. This disseminative failure perplexes more than it clarifies. The following scene perhaps epitomizes the poor transmission of information. It features footage from the first 2016 US presidential debate with both words and images reduced to a distorted nonsense (i.e. hardly changed at all). Finally, a series of quickly flashing images of people are peppered with longer shots of death and discomfort, brought to the brink of absurdity.

The construction itself has an order (five carefully arranged blocks with computer monitors in each one), as well as a chaos (junk technology and duct tape litter the structure). I designed this visual component in order to lure the observe into rationalizing the seemingly unintelligible disarray of materials. The observer might not know what s/he is seeing, or s/he may also order the mayhem into something comprehensible and meaningful, depending on his or her biases and experiences. I hope this process helps spark some insight into my own considerations about the origin of thing/event qualities. After all, if one constructs an individual explanation for why the materials are present and what they mean, one consciously applies certain characteristics to the installation. I think this procedure reflects the much more automatic way in which the mind otherwise applies attributes to things/events.

The once viable technologies that litter the project—tapes, CDs, analog television sets, cables, and more—further highlight the theme of information transmission. In this case, they no longer operate with their intended sound- and video-production capacities and instead act as little more than decoration. These devices, I suppose, leave a clue as to the qualities within our reality after the mind ceases to function. It is not, I believe, a world merely devoid of characteristics, just as the technology produces no sound or video, but, necessarily, a nothingness empty of perception and experience.



1. Obscure Angle



Single shot. Placement of camera on ground at strange angle catches very close shifting object (too close to know what it is) and a distant haze (too far to make out characteristics). Quality is grainy, distorted, recolored, and repeatedly overexposed. Manipulated sounds from an enigmatic source that was mangled through a cell phone recording accompany the changes in motion.

Duration: ~4'

2. Distant Violinist



Violinist performs simple folk tune in desert setting, complete with concert dress. Shot is from a significant distance, making the performer fairly small, and a major road separates him from the camera. The violinist's music is almost completely covered by traffic, which is amplified, processed, and distorted.

Duration: ~1'

3. About?

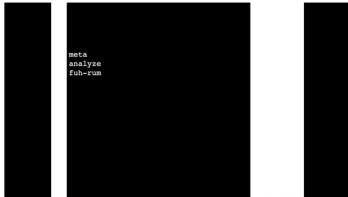

Some poetry flashes by that almost tries to explain the project in phenomenological speak. Words are scrambled, confused, and otherwise difficult to comprehend. Fuzzy screens and white noise interrupt the rich, yet brief, sounds derived from popular music recordings.

Duration: ~2'

4. Civil Clinton Vs. Civil Trump



Footage from the first presidential debate of 2016 repeatedly reprocessed and distorted until nearly unrecognizable. Colors are overwhelmingly stark and bright. For sound, their words are filtered into granular nonsense.

Duration: ~4'

5. Fleeting Images



Stock footage in split-second durations spliced together into flashes of images. The material embodies any and all forms of communication, work, and human existence. Pauses in the violent stream typically highlight death. Fleeting bits of randomly synthesized audio, including sine tones, triangle waves, and saw waves, follow the video 1-to-1.

Duration: ~1'

Materials

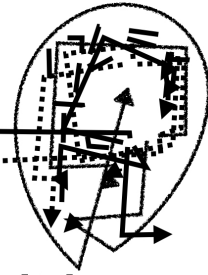

- Computer monitors with built-in speakers [5x]
- Analog televisions, 18-30" [5x]
- Laptop computer with HDMI port (or supply an adaptor) [1x]
- 6' and 10' HDMI cables [5x]
- 50'+ HDMI cable [1x]
- HDMI 1-to-8 Splitter (1-to-5+ acceptable) [1x]
- Extension cords [3x, as needed]
- Power Strips [2x]
- Roll of Gaff Tape [1x]
- 9.5' x 4' x 4' custom-built tower [1x]
 - 4' x 4' base [1x]
 - 29-3/4" x 21" x 21" bottom box [1x]
 - 21" x 21" x 21" middle boxes [3x]
 - 21" x 21" x 21" top box with hook fastened to center [1x]
 - Screws [16x]
 - Nuts, bolts, and washers to fasten together boxes [8x]
- Wire cords for securing the top [4x]
- mp4 video file played from Quicktime or another viable program [1x]
- Excessive outdated junk technology, including, but not limited too...
 - Video tapes
 - CDs
 - Laser disks
 - Cassettes
 - Video game controllers
 - Stereo wire
 - RCA connectors
 - Printer cables
 - Various chargers
 - Computer keyboards
 - Duct tape
 - Anything and everything that doesn't work anymore

Materials may need modification in order to fit the space

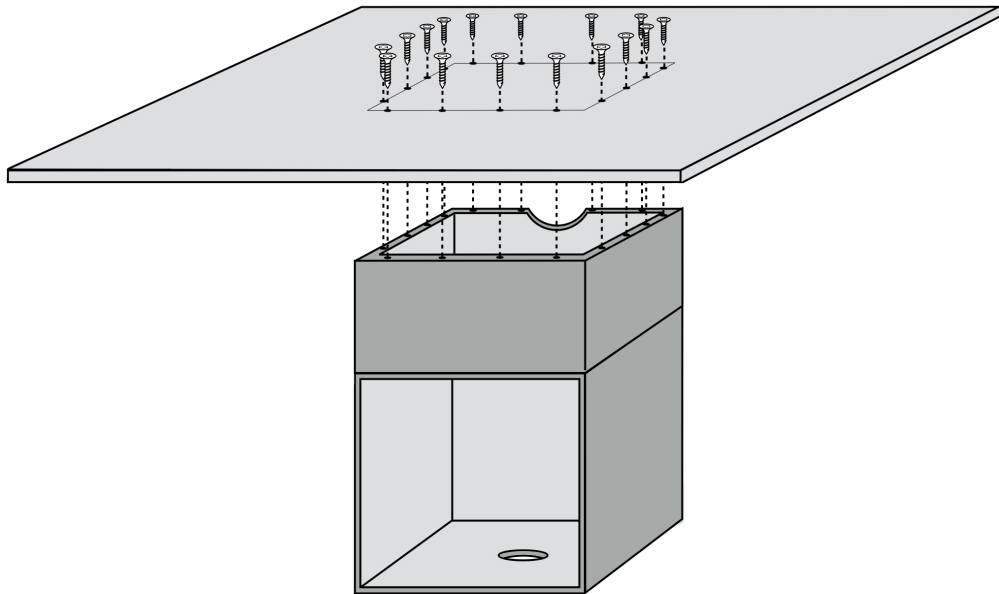
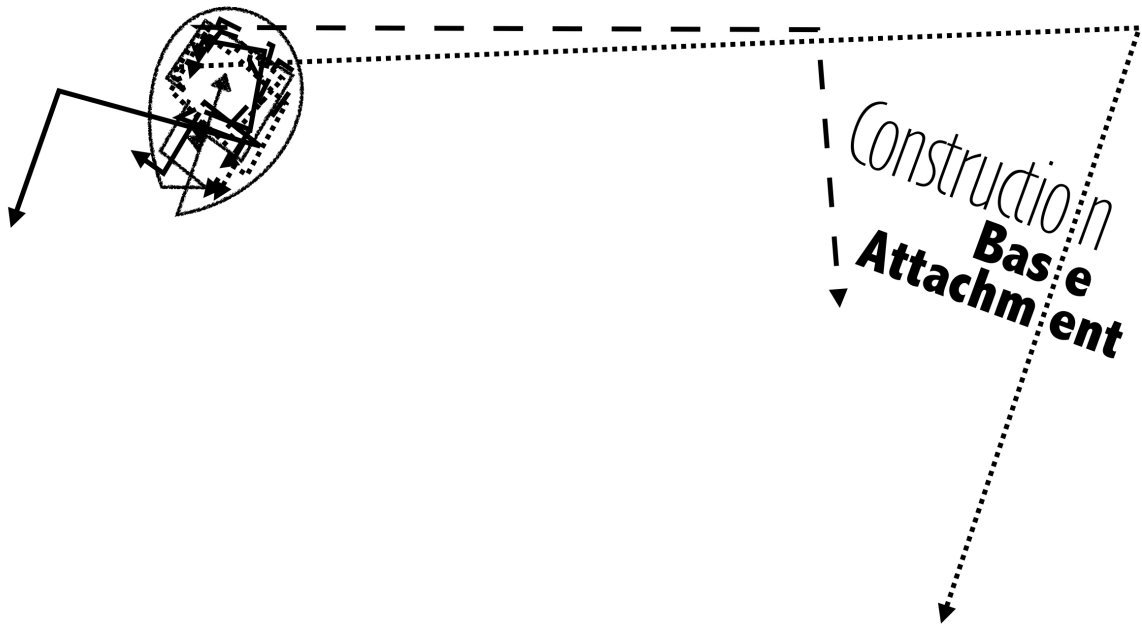

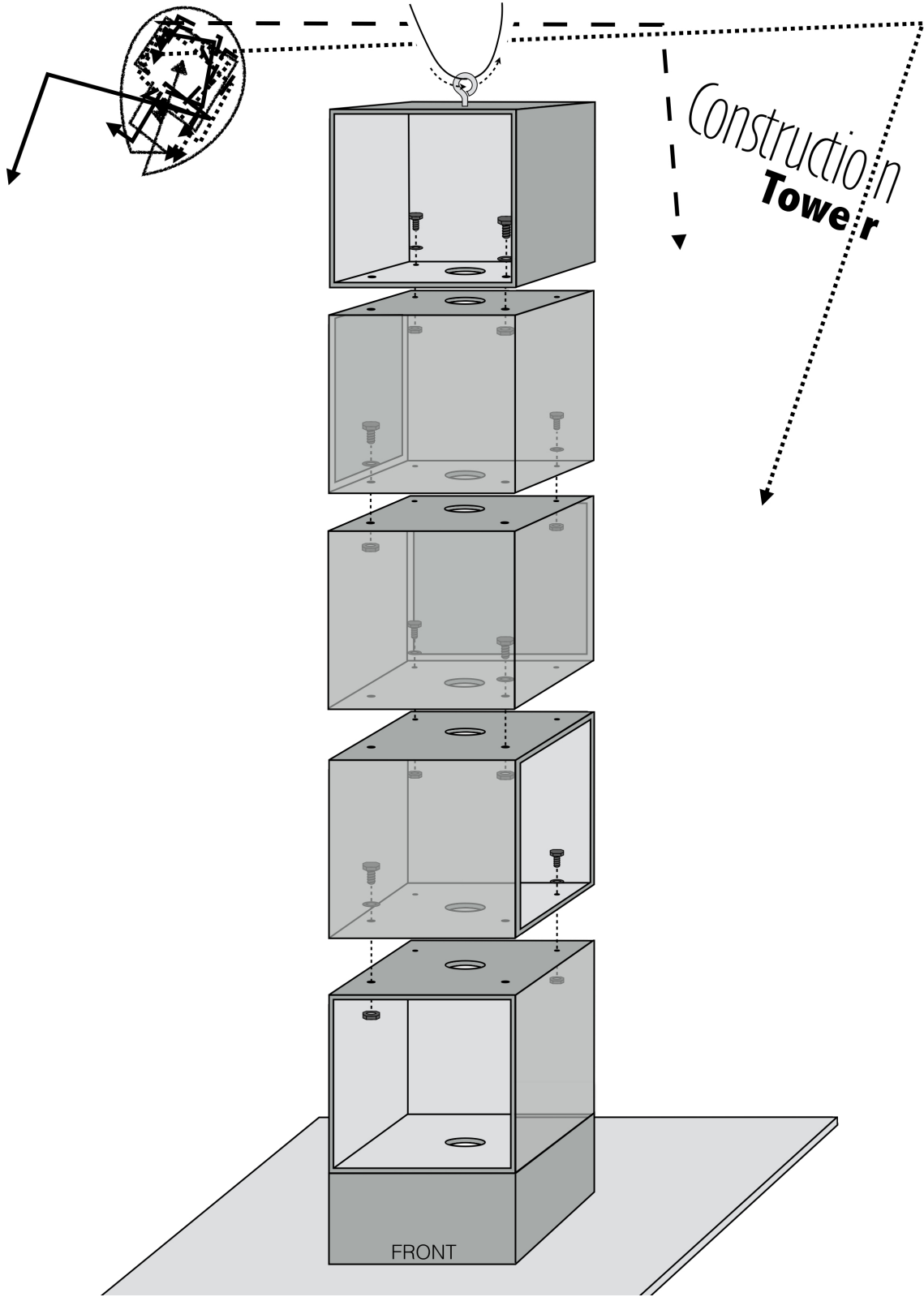

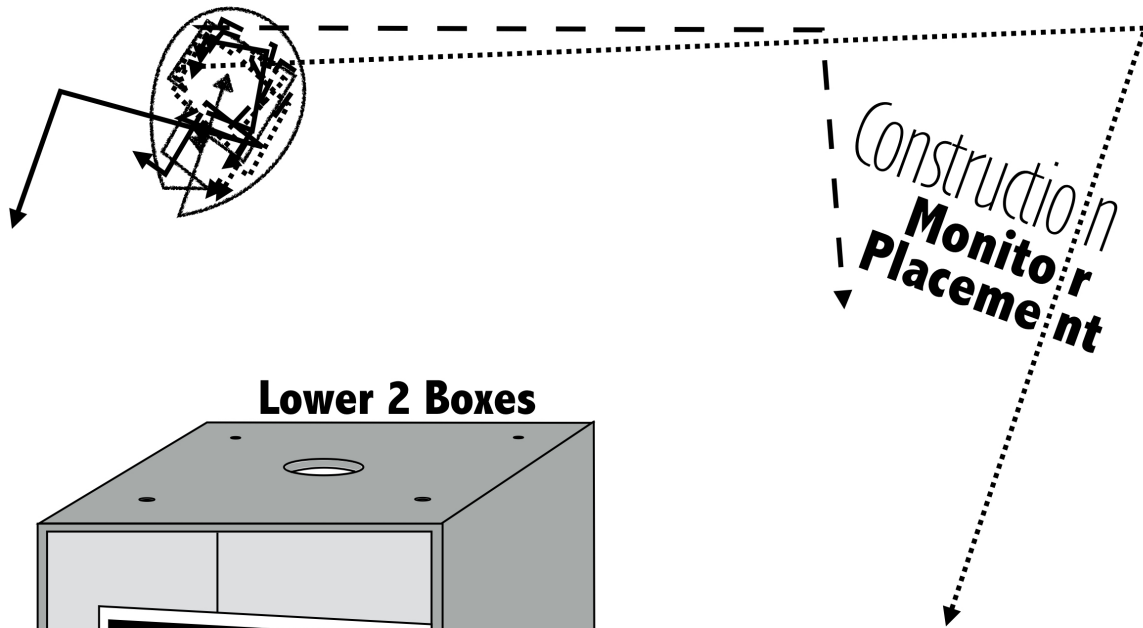

Lower 2 Boxes

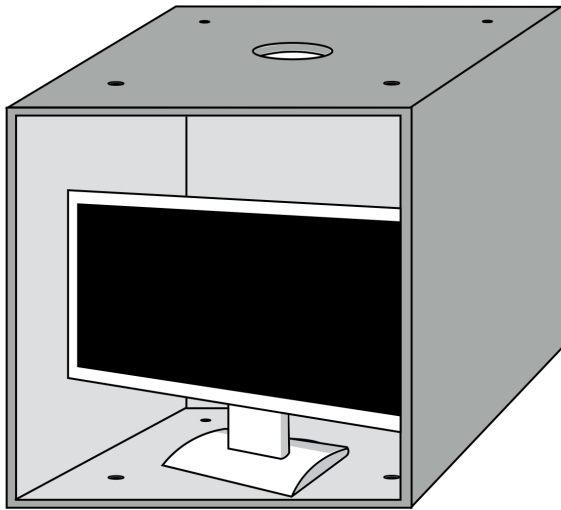

Upper 3 Boxes

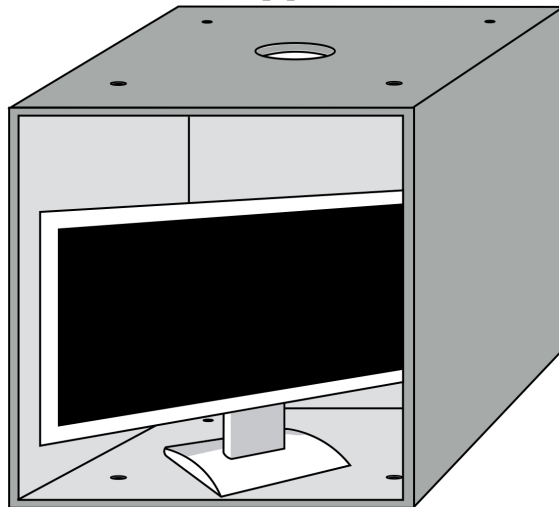

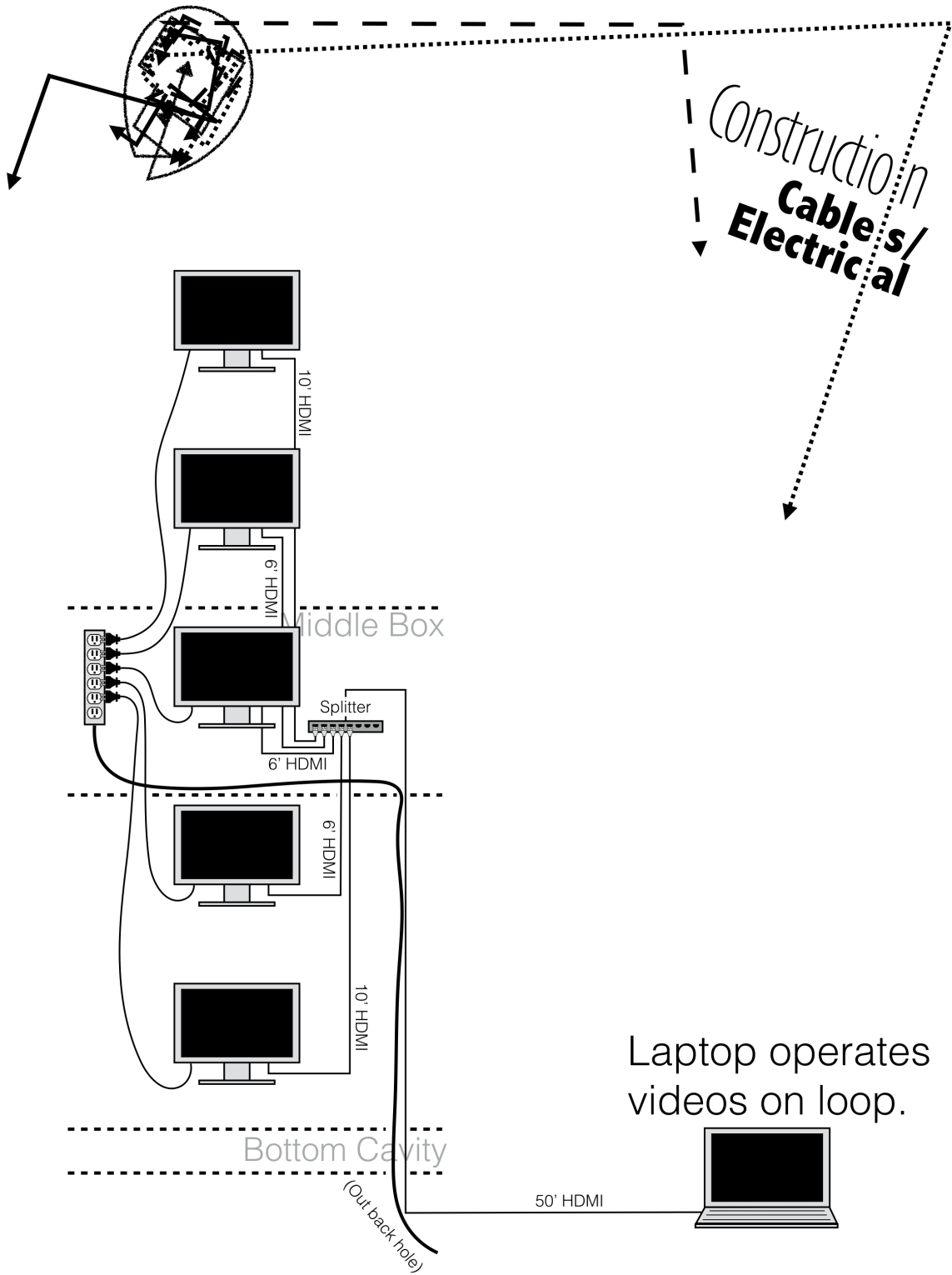

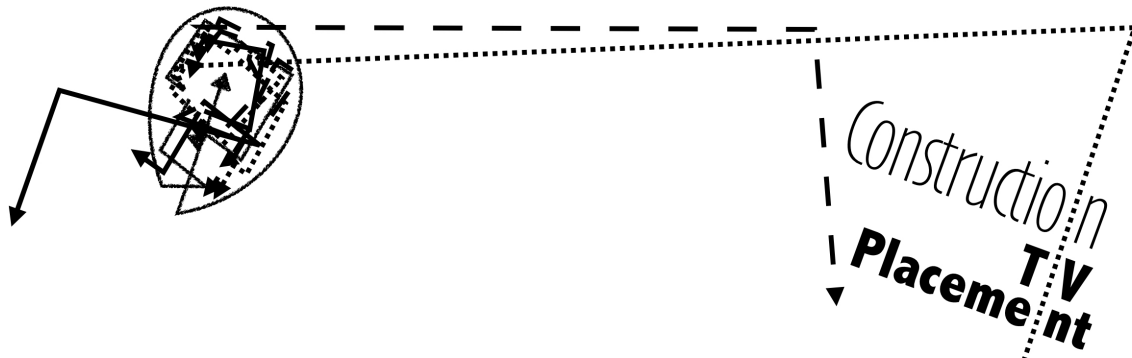

All plugged in TVs turned to static or blue screens.

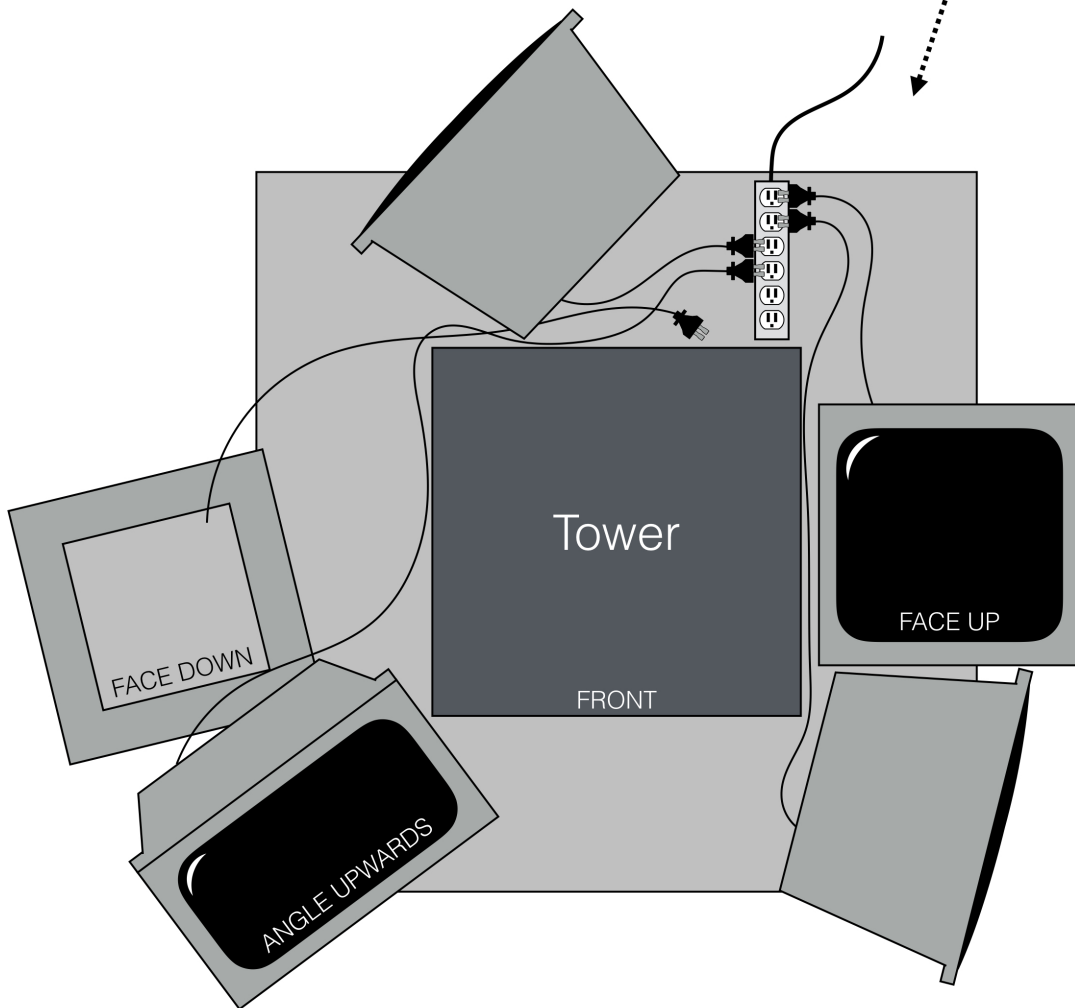

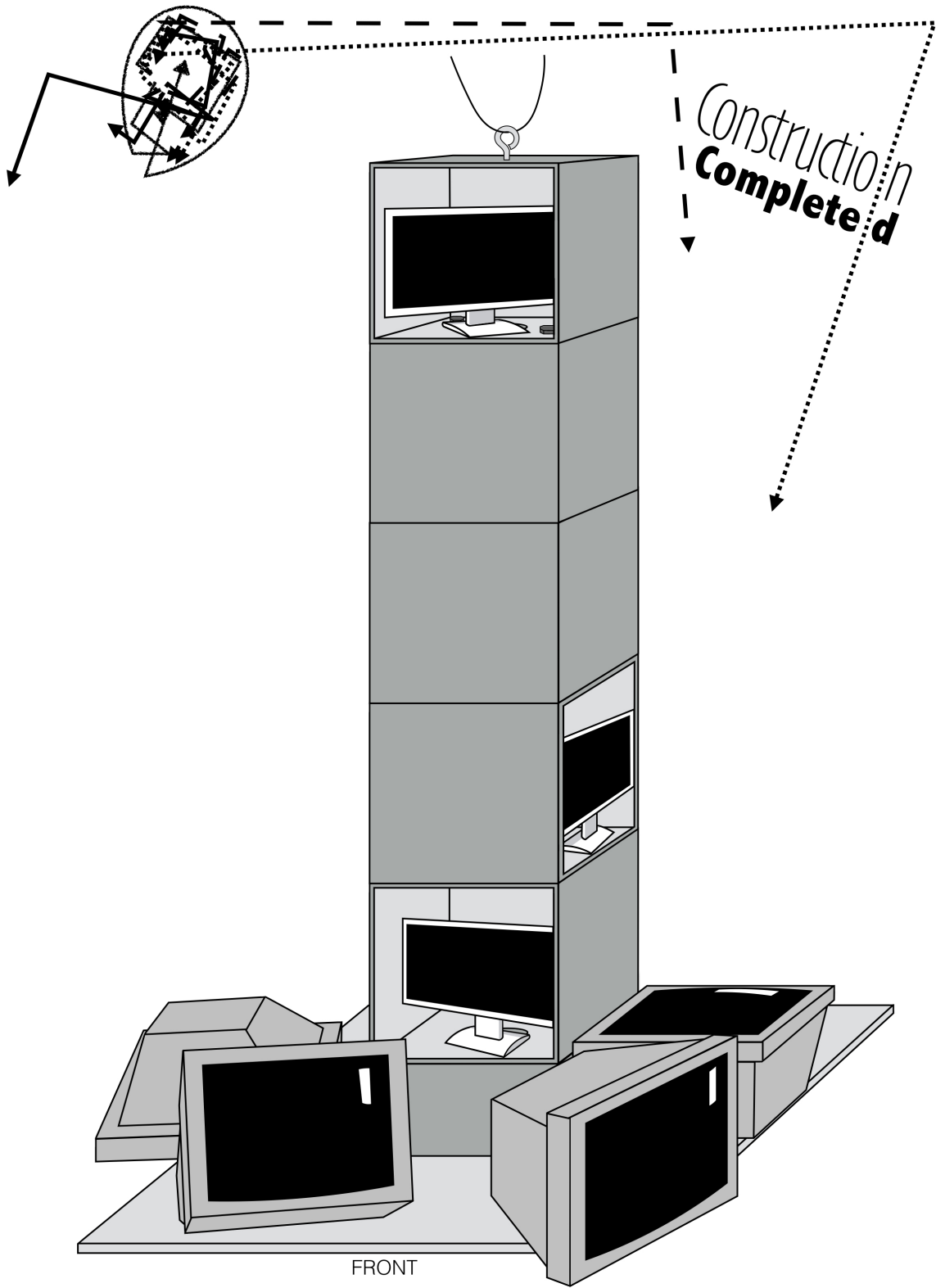

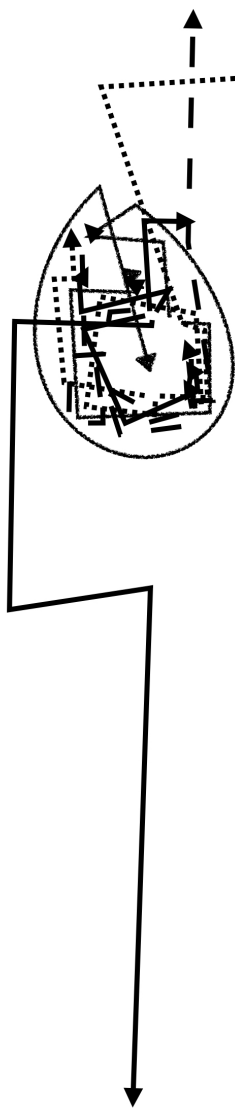

Photo Examples

